

Layher UniStairTower

Mobile access and working towers
in accordance with: HD 1004;
DIN 4422, Part 1 (Version 8/92)

Working platform 1.5 x 1.8 m

Max. working height:
in closed rooms 14.5 m, outdoors 8.5 m

Permissible load 2 kN/m²
on max. one working level:
scaffold group 3 acc. to HD 1004;
DIN 4422, Part 1 (Version 8/92)



Aluminium Rolling Towers

Instructions for Assembly and Use



Layher® 

More Possibilities. The Scaffolding System.

Tower Types

For **outdoor use** observe height limits.

Layer UniStairTower

Tower models 4201-4203



Tower model	4201	4202	4203
Working height (m)	4.5	6.5	8.5
Scaffold height ¹⁾ (m)	3.7 (3.45)	5.7 (5.45)	7.7 (7.45)
Platform height (m)	2.5	4.5	6.5
Weight (kg)	178.8	253.8	417.1

¹⁾ Values in brackets: minimum tower height incl. spigots.

Tower models 4204-4206

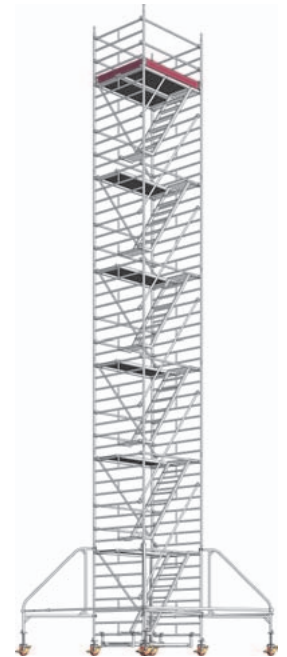
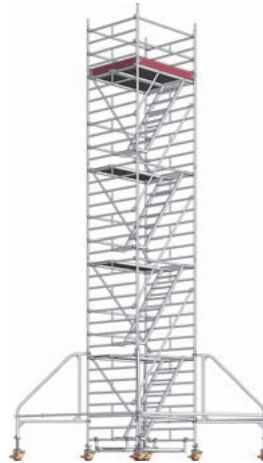

Tower model	4204	4205	4206
Working height (m)	10.5	12.5	14.5
Scaffold height ¹⁾ (m)	9.7 (9.45)	11.7 (11.45)	13.7 (13.45)
Platform height (m)	8.5	10.5	12.5
Weight (kg)	492.1	567.1	642.1

¹⁾ Values in brackets: minimum tower height incl. spigots.

Assembly

- 1 Pay attention to the General Assembly and Use Instructions on page 8. The examples shown of the tower types 4205 – 4206 (page 2) are designed for use indoors. According to the regulations in force since January, 1st, 1987, the permissible **maximum platform height outdoors is 8 m**. Pay attention to the material list and ballasting table on page 7.

►2 Basic assembly Tower models 4201 and 4202



Insert the castors 1 into the ladder frames 4 and secure against falling out by fastening the wing screws on the spindle nuts.

Connect the two ladder frames 4 with one guardrail 5 onto the 1st rung from the bottom. Snap-on the diagonal brace 6 at the entrance side to stabilize the ladder frames 4.

Fix the deck support 4 at the correct distance below the ladder frames 4 (see detail). Bolt the base strut 17 to the deck support 14.

Insert the deck 1.8 m 10 into the deck support 14 directly beside the base strut 1.8 m 17. Mount the stair with landing 7. The stair with landing 7 must always be built in at the right-hand side of the tower – seen from the direction of ascent. (Pay strict attention to the assembly examples.) If you fail to observe this arrangement, the access deck 9 at the top platform will be placed on the wrong side.

As protection mount one stair guardrail 5 onto the top rung of the ladder frame 4; on the opposite side of the stair 7 lock in the deck 10. Level the tower using the threaded spindles.

After assembly push guardrails 5 and diagonal braces 6 outwards as far as possible.

For the following assembly steps for tower type 4201 see chapter 4 and for tower type 4202 see chapter 3.

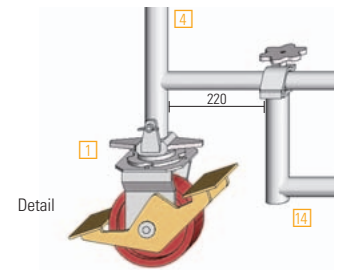

Tower models 4203–4206, 4212, 4222 with outriggers

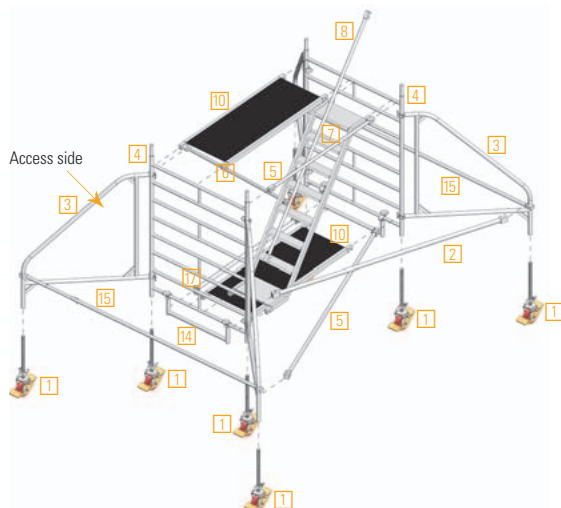

For **models 4203** onwards insert the castors 1 into the outrigger 3 and secure against falling out by fastening the wing screws on the spindle nuts. Connect four outriggers 3 with rapid couplers, the lower coupler being placed under the 2nd rung of the lower ladder frame 4. Before you fasten the hand wheel fix the outriggers 3 with the two horizontal braces 2 in their correct position. Then fasten the hand wheels fingertight.

The next step will be the fixing of the two adjustable horizontal braces 15 in order to connect the two outriggers 3 in each case. The horizontal braces 15 must be built in parallel to the ladder frames 4. Thus you keep the entrance area free (see also page 7, drawing for ballast fixing).

When working next to a wall, you may use a tower with outriggers 3 on one side only. Pay attention to the ballasting tables.

For the following assembly steps see chapter 3.

Assembly

Layer UniStairTower

►3 Assembly of the intermediate platforms

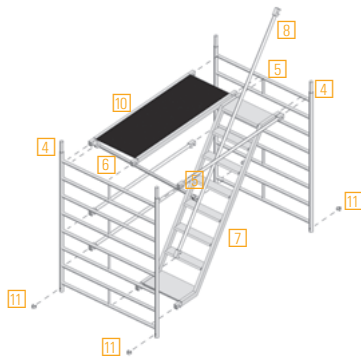

During assembly and dismantling, system decks or scaffold planks according to DIN 4420 (minimum: 28 x 4.5 x 250 cm long) must be used as auxiliary decks at maximum height intervals of 2.0 m. These auxiliary decks provide a safe footing for assembly and dismantling, are removed after the erection. Each platform must be completely boarded.

To continue follow the assembly examples (page 2). Plug in the ladder frames [4] and secure them with spring clips [11]. Take care that the following stair with landing [7] is always inserted one rung higher (25 cm) than the opposite deck [10] at its lowest end.

The diagonal braces [6] are always built in the opposite direction to the stair [7]. The stair rails [8] have to be built in and fixed at the lower end of the stair [7] to the 3rd rung above the landing.

At the intermediate platforms, which must only be used for ascending, two guardrails [5] are fixed on the outside for lateral protection.

Do not add the next platform until the uppermost platform below is completely mounted and braced.

For dismantling proceed in the reverse order, i.e. do not start dismantling the next platform until the upper one is completely dismantled. After assembly push guardrails [5] and diagonal braces [6] outwards as far as possible.

For following assembly steps see chapter 4.

►4 Assembly of the working platform

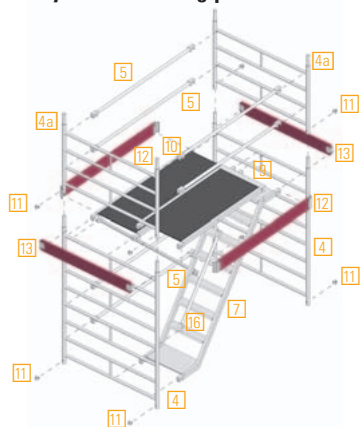

At the level of the top stair head build in the stair-access deck [9]. First slot the support into the staircase [7] so that the bottom flange grips underneath the landing. Then lower the stair-access deck [9] down and lock it into the top rung of the opposite ladder frame [4]. This secures the stair-access deck [9] against unintended lift-off or displacing.

Now place the deck 1.8 m [10] beside the stair-access deck 1.8 m [9]. The horizontal gap between the two decks is a maximum of 25 mm. Mount stair rail 1.2 m [8] at the 4th rung of the ladder frame [4] from the bottom and fix the upper part of the rail with bolts to the frame of the access deck [9].

Then plug in two ladder frames [4a] and secure them with spring clips [11]. Add the safety protection according to regulations consisting of two guardrails [5] at each side as well as two toe boards 1.8 m [12] and two end toe boards 1.44 m [13].

After assembly push guardrails [5] and diagonal braces [6] outwards as far as possible.

►5 Operating the castors

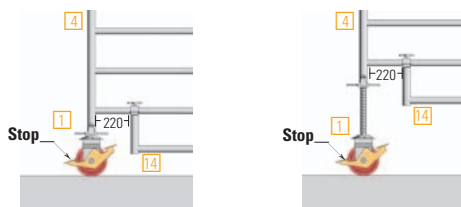

Maximum height adjustment at the spindle = 25 cm

During assembly and while working, the castors [1] must be kept locked by pressing down the brake lever labelled STOP. When the brake is locked, the lever labelled STOP is in the down position.

For movement, the castors are unlocked by pushing the other lever down.

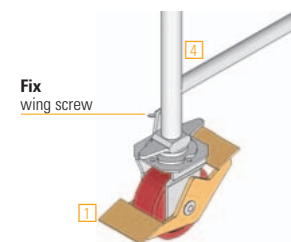

▶ Wall Support

Layher UniStairTower

Wall support under load

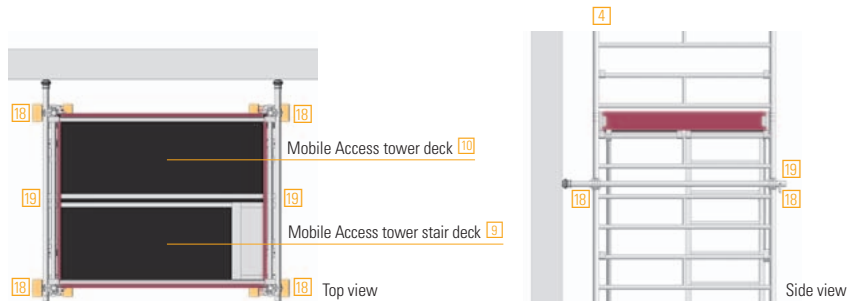

When working next to a wall, supports may be required according to the table **“Ballasting”** (page 7). Use the Uni-distance-tube 19 and fix it to the ladder frames 4 with the couplers 18.

▶ Dismantling

During assembly and dismantling, system decks or scaffold planks according to DIN 4420 (minimum 28 x 4.5 x 250 cm long) must be built in as auxiliary decks at maximum height intervals of 2.0 m. These auxiliary decks, providing a safe footing for assembly and dismantling, are removed after the erection. Each platform must be completely boarded.

Remove the corresponding diagonal braces 6 and bracing elements only after having taken down the ladder frames 4, 4a situated above.

Dismantling is carried out in the reverse order of assembly.

To remove parts open the snap-on claws by depressing the locking clips. The red claws of the decks enable a single person to assemble or dismantle them easily; open them at one end and rest the base of the clips on the rung. Now open the opposite clips and remove the deck.

Components

Layer UniStairTower

1 **Castor 200**
with spindle 7 kN
and wing screw

1259.200



2 **Horizontal brace**
2.95 m

1209.285



3 **Outrigger**

1216.000



4a **Ladder frame 150/4**

1299.004

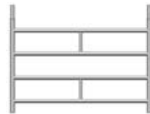

4 **Ladder frame 150/8**

1299.008

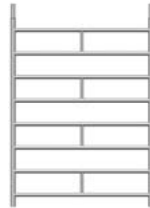

5 **Guardrail**
1.8 m

1205.180



6 **Diagonal brace**
2.5 m

1208.180



7 **Stair with landing**
1.8 m

1212.180



Stair rail

8 3.07 m
16 1.2 m

1213.180

1327.120



9 **Stair-access deck**
1.8 m

1243.180



10 **Deck**
1.8 m

1241.180



11 **Spring clip**

1250.000



12 **Toe board with claw**
1.8 m

1239.180



13 **End toe board**
1.44 m

1238.144



14 **Deck support to screw on**
0.9 m

1326.090



15 **Horizontal brace, aluminium**
adjustable

1318.000



17 **Base strut**
1.8 m

1324.180



18 **Special double coupler, rigid**
WS 19 mm
WS 22 mm

1269.019

1269.022



19 **Uni-distance-tube**
1.8 m

1275.180



20 **Ballast**
10 kg

1249.000



Parts List

Towers **4212** (outriggers at one side) and **4222** (outriggers at both sides) are intended for **outdoor use**. Assembly of the outriggers according to description on page 3.

Tower Model	Reference	4201	4202	4212	4222	4203	4204	4205	4206
Ladder frame 150/4	1299.004	2	2	2	2	2	2	2	2
Ladder frame 150/8	1299.008	2	4	4	4	6	8	10	12
Stair-access deck 1.8 m	1243.180	1	1	1	1	1	1	1	1
Deck 1.8 m	1241.180	2	3	3	3	4	5	6	7
Guardrail 1.8 m	1205.180	5	8	8	8	11	14	17	20
Diagonal brace 2.5 m	1208.180	1	2	2	2	3	4	5	6
Stair with landing 1.8 m	1212.180	1	2	2	2	3	4	5	6
Stair rail 3.07 m	1213.180	–	1	1	1	2	3	4	5
Stair rail 1.2 m	1327.120	1	1	1	1	1	1	1	1
Toe board 1.8 m, with claw	1239.180	2	2	2	2	2	2	2	2
End toe board 1.44 m	1238.144	2	2	2	2	2	2	2	2
Outrigger	1216.000	–	–	2	4	4	4	4	4
Horizontal brace 2.95 m	1209.285	–	–	2	2	2	2	2	2
Adjustable horizontal brace	1318.000	–	–	–	2	2	2	2	2
Base strut 1.8 m	1324.180	1	1	1	1	1	1	1	1
Deck support to screw down, 0.9 m	1326.090	2	2	2	2	2	2	2	2
Spring clip	1250.000	4	8	8	8	12	16	20	24
Castor 200 with spindle, 7 kN	1262.200	4	4	6	8	8	8	8	8
Ballast	1249.000	For the number of ballast weight see the Ballasting table.							

Ballasting

In order to ballast the tower use Layher ballast weights [20](#), Ref. 1249.000 (10 kg each). Coupler with hand wheel permits simple, quick and secure fixing of the respective ballast required at the correct places. Only these ballast weights are to be used, **liquid or granular ballast materials must not be used**.

The ballast weights must be distributed evenly to all ballasting fixing points. The remainder, not divisible by 4, is distributed to the fixing points A.

Tower Model		4201	4202	4212	4222	4203	4204	4205	4206
Indoor use	Without outriggers	○	6	×	×	×	×	×	×
	Two sided outriggers	□	□	×	○	○	○	○	○
	One sided outriggers	□	□	2	×	2	4	6	8
	One sided outriggers with wall support	□	□	○	×	○	○	○	○
Outdoor use	Without outriggers	2	16	×	×	×	×	×	×
	One sided outriggers	□	□	8	×	20	×	×	×
	Two sided outriggers	□	□	□	○	○	○	×	×
	One sided outriggers with wall support	□	□	○	×	○	4	×	×

The figures shown indicate the number of ballast weights 10 kg each. ○ = no ballast required. × = not permitted. □ = Erection with additional parts, only possible after consulting the manufacturer.

How to position the ballast weights

○ = fixing points for ballast weights
 A = fixing points for remainder of ballast weights not divisible by 4

Without outriggers (top view)

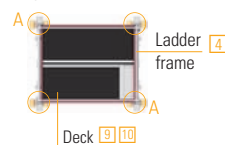

With one sided outriggers (top view)

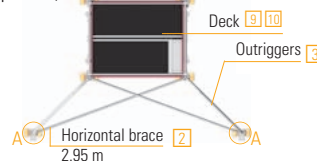

With outriggers both sides (top view)

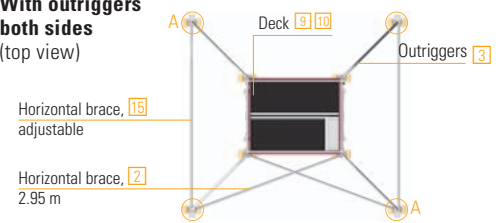

General Instructions on Assembly and Usage

Layher UniStairTower

The rolling tower may be used for the scaffolding group and as additionally specified in the German operating safety regulations (BetrSichV). The rules of the German professional associations governing the building of rolling towers (BGR 172/April 2000) and of small scaffolding units (BGR 173/April 2000) must be complied with. For mobile working platforms (rolling towers), DIN 4422 Part 1 (issue 8/92) applies. For small scaffolding units (platform height ≤ 2 m), BGR 173 applies.

The user of mobile working platforms must comply with the following instructions:

1. The user must check the suitability of the selected rolling tower for the work to be performed (Section 4 of BetrSichV).

2. The max. platform height is, in accordance with DIN 4422 Part 1:

- inside buildings 12.0 m
- outside buildings 8.0 m

The material and ballasting requirements on page 7 must be complied with; risk of accidents in the event of non-compliance. For greater heights, additional measures are necessary, obtainable from the manufacturer. Stability of the rolling tower must be assured.

3. The assembly, modification or dismantling of the rolling tower in accordance with the present instructions for assembly and use may only be performed under the supervision of a qualified person and by professionally suitable personnel after special instruction. Only the scaffolding types shown in these instructions for assembly and use may be used. The unit must, after assembly and before being put into service, be inspected by persons qualified to do so (Section 10 of BetrSichV). The inspection must be documented (Section 11 of BetrSichV). During assembly, modification or dismantling, the rolling tower must be provided with a prohibition sign indicating "No access allowed" and be adequately safeguarded by means of barriers preventing access to the danger zone (BetrSichV Annex 2, para. 5.2.5).

4. Before starting assembly, examine all components in order to make sure they are in perfect condition. Only undamaged original components for Layher Mobile Working-Platformsystems may be used. Tower parts such as snap-on claws and spigots must be cleaned of dirt after use. Tower parts must be protected against slipping and impacts during truck transportation. It must be ensured that the tower parts are stored where they are free from weather effects. Tower parts must be handled in such a way that they are not damaged.

5. During assembly and dismantling, system decks or scaffold planks according to DIN 4420 (min. 28 x 4.5 x 250 cm long), must be built in as auxiliary decks at max. height intervals of 2.0 m. These auxiliary decks, providing a safe footing for assembly and dismantling, are removed after the erection. Each platform must be completely boarded.

Due to structural reasons intermediate platforms with access decks must be built in at maximum intervals of

4.0 m. For safety reasons, it is advisable for two persons to erect the towers above a height of 4.0 m. To assemble the upper tower sections, the individual parts must be hoisted using transportation ropes.

The attachment of lifting gear for vertical transportation, e. g. of tools or materials, requires approval based on a special structural analysis. Small quantities of tools and materials can be carried up in person, otherwise hoisted by transportation ropes to the working level.

6. Secure the ladder frame joints with spring clips against unintended lift-off.

7. During assembly push guardrails and diagonal braces outwards as far as possible on the ladder rungs.

8. At intermediate decks used for climbing only, two guardrails are required. For small towers where the height of the deck exceeds 1.0 m, equipment must be provided that permits the attachment of side guards in accordance with DIN 4420-1.

9. Access to the working platform is only permitted on the inside.

10. It is not permitted to work on two or more decks at the same time. In the event of discrepancies consult the manufacturer.

11. Persons working on mobile platforms should not lean or press against the guardrails, nor jump onto platforms.

12. It is not permitted to affix lifting or hoisting devices to mobile working platforms.

13. Move the tower manually and only on firm, level ground which is free from obstacles and sufficiently load bearing. Move the tower only longitudinally or diagonally. Avoid any impact. Do not exceed normal walking speed during movement. After extending the base one sided with wall supports in use, move parallel to the wall only.

14. No persons or loose objects must remain on the tower when moving it.

15. Before use and after moving the tower, lock the castors by pressing the brake lever.

16. Do not expose the tower to corrosive liquids or gases.

17. Mobile working platforms must not be bridged between each other, or a building **without special verification**. The same applies to special erections, e. g. suspended use etc.

18. At a wind force above 6 (Beaufort-Scale) and after finishing the working shift, move the tower when **operating outdoors** or in open buildings to a wind protected area or secure it by other appropriate measures against toppling over. (Wind speeds above 6 on the Beaufort-Scale can be recognised by noticeable difficulty when walking.) If possible, rolling towers used on the outside of buildings must be securely attached to the building or to another structure. It is recommended that rolling towers be anchored when they are left unattended.

19. Set the rolling tower verhedly with the adjusting spindles, or by placing suitable materials underneath it. The inclination must not exceed 1 %.

20. Keep the access hatches shut, except when climbing the tower.

21. All couplers must be fastened with 50 Nm.

22. A rolling tower is not intended for use as a stairway tower providing access to other structures.

23. It is prohibited to jump on the decks.

24. A check must be made that all parts, auxiliary tools and safety equipment (ropes etc.) for erecting the rolling towers are available on the site.

25. Avoid horizontal and vertical loads that can cause the mobile work platform to topple over, such as - horizontal loads, for example when working on adjacent structures

- additional wind loads (due to tunnel effect from through-type building, unclad buildings and corners)

26. When stipulated, mobile beams or outriggers and ballast must be installed.

27. It is prohibited to increase the height of the decking by using ladders, boxes or other objects.

28. It is not permitted to construct bridges between the rolling tower and a building.

29. Rolling towers are not designed to be lifted or suspended. If their use as suspended scaffolding is planned, for example, consult the manufacturer.

All dimensions and weights are for guidance only. Subject to technical modifications.

Sales exclusively on the basis of our currently valid general terms of business.

Layher® 

More Possibilities. The Scaffolding System.

Wilhelm Layher GmbH & Co. KG
Scaffolding Grandstands Ladders

Post Box 40
D-74361 Güglingen-Eibensbach
Phone: **49-71 35-7 00
Fax: **49-71 35-7 03 72
E-mail: export@layher.com
<http://www.layher.com>